



KETUJUH[®]
— SQUARE —

ULTIMATE
EXPERIENCE,
DESIGNED
FOR MODERN
ASPIRATION.



A COMMERCIAL & LIFESTYLE EVOLUTION

NATION'S 1ST CURATED HUB OF TOMORROW

Introducing Ketujuh Square (K7), the catalyst for a new era in Section 7, Shah Alam. This modern landmark of commerce and lifestyle is designed to elevate the urban experience for those who demand more.

An all-in-one destination, it combines thoughtfully curated spaces, smart technology and sustainable features to create a resilient ecosystem that supports growth and longevity.

Guided by principles of design excellence, K7 serves as the strategic core of convenience, offering a dynamic environment where businesses thrive and community is celebrated.

Every detail here fosters balance and purpose.
This is where the future of Shah Alam begins – K7.

ALL IN 1 HUB

- ◆ Automated Parking
- ◆ Departure Lounge
- ◆ Market Hall
- ◆ Personal Wellness
- ◆ High Street
- ◆ Education & Enrichment
- ◆ Lifestyle Suites
- ◆ Business Facilities
- ◆ Modern Surau
- ◆ Infinity Pool



ANCHORING SHAH ALAM'S CORE

K7'S LOCATION ADVANTAGE

K7, Shah Alam is strategically located at the heart of a 40-year-old mature township. It is a thriving address where academic energy, professional activity and established communities converge to form a continuous cycle of demand and activity.

Strategically positioned as the primary anchor of its surrounding growth corridor, K7 is seamlessly integrated with CBDs, universities, healthcare institutions and government hubs. This convergence ensures a steady flow of both permanent residents and transient populations, from students and medical visitors to working professionals and young families.

Well-connected via the Federal Highway and major expressways, with enhanced accessibility through the LRT 3 line, K7 enjoys seamless regional and citywide connectivity. Located just 15 minutes from Klang and 30 minutes from Kuala Lumpur, it is within a high-consumption catchment.

◆ Mature Township

◆ Vibrant Demographic

- Transient Population (Daily Inflow & Outflow)
- Fixed Residents (Established Stability)

◆ Prime Address

◆ Connected Infrastructure

◆ Higher Spending Power



KETUJUH
— SQUARE —

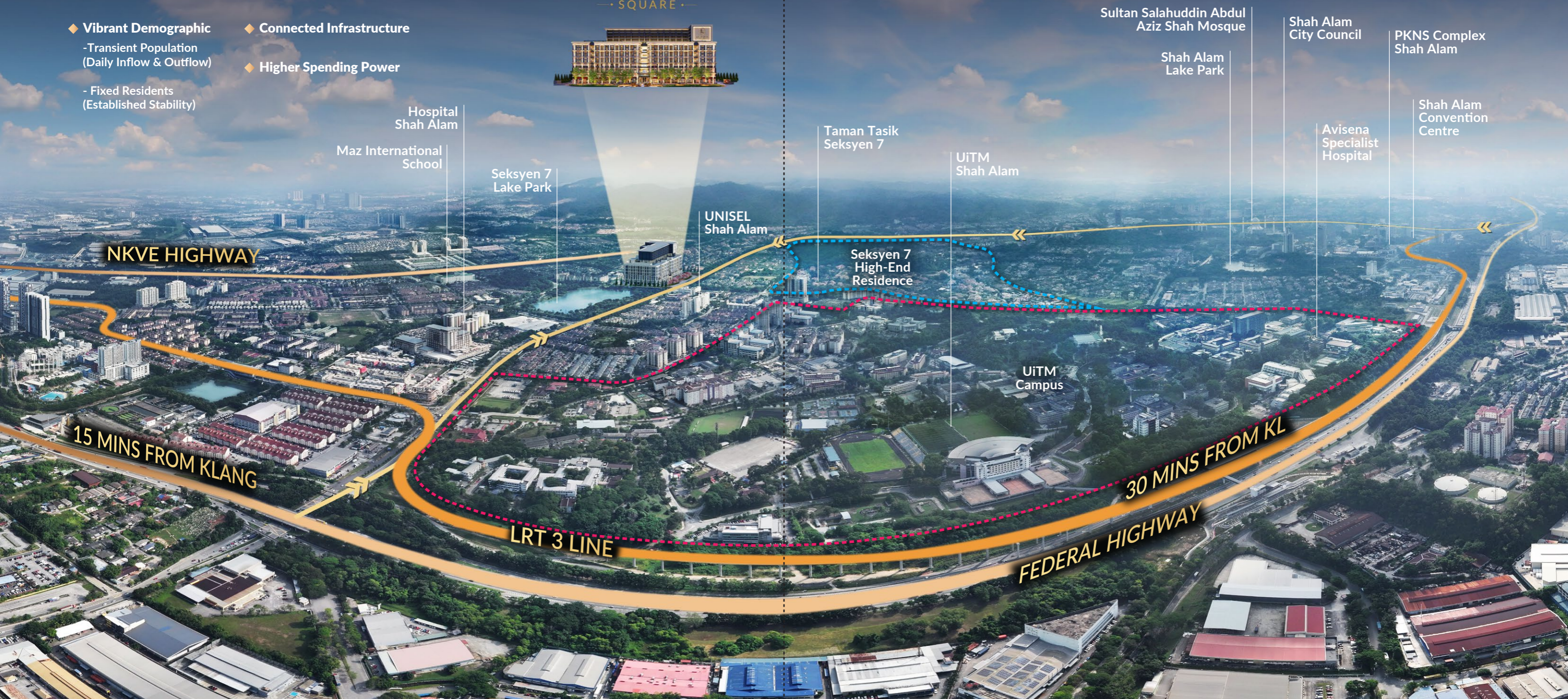

Hospital Shah Alam
Maz International School

Seksyen 7 Lake Park

UNISEL Shah Alam

Taman Tasik Seksyen 7

Seksyen 7 High-End Residence

UiTM Shah Alam

UiTM Campus

Sultan Salahuddin Abdul Aziz Shah Mosque

Shah Alam Lake Park

Shah Alam City Council

Avisena Specialist Hospital

PKNS Complex Shah Alam

Shah Alam Convention Centre

15 MINS FROM KLANG

LRT 3 LINE

30 MINS FROM KL
FEDERAL HIGHWAY

POPULATION

OVER **700,000**

ETHNICITY

- MALAY / BUMIPUTERA
- CHINESE
- INDIAN
- OTHER ETHNICITIES

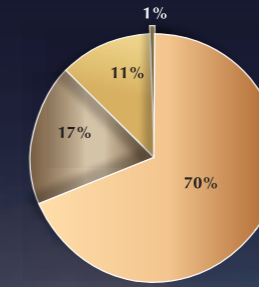

Sources: Department of Statistics Malaysia (DOSM) MBSA / Kawasanku (MBSA City Boundary) | MyCensus 2020.



Architectural Rendering

SEAMLESSLY CONNECTED

UNRIVALLED ACCESS
FLUID MOBILITY

K7 stands at the intersection of unmatched accessibility and urban intelligence, positioned within a prime regional district. Its design accommodates major transportation nodes, further anchored by the 'iconic bus stop'; a transit hub that integrates flawlessly with city-wide routes.

Beyond vital transport axes, K7 prioritises a 'pedestrian-first' philosophy. Our walkable paths along the stunning landscape, enables more than fluid mobility, enhancing the patron experience through effortless connections.



Architectural Rendering



CRUCIAL TRANSPORTATION CORRIDORS



CONNECTED VIA FEDERAL HIGHWAY, LKSA EXPRESSWAY, NKVE, KESAS & ELITE.



ACCESSIBLE VIA PUBLIC TRANSPORT, I.E., NEW LRT 3, BUSES & KTM STATIONS.

AN ARCHITECTURE OF MODERN SOPHISTICATION

TIMELESS ELEGANCE ♦ PEOPLE-CENTRIC ♦ SAFE

K7 blends timeless monumental architecture with a refined commercial environment.

Every element is designed with people in mind, creating a vibrant, welcoming and green-conscious setting. Wide, pedestrian-friendly pathways, open gathering spaces and a signature cherry blossom landscape, form a striking visual identity that encourages a continuous flow of movement and interaction.

Seamless inter-level connectivity, smart technology, accessible facilities and integrated safety systems make K7 the destination for ultimate lifestyle and business experiences.

To ensure the property remains in impeccable condition for generations, K7's Smart-Zeroisation model leverages revenue-generating assets to cover building maintenance, creating a self-sustaining ecosystem.

- ♦ Monumental & Timeless
- ♦ Purpose Driven Design
- ♦ Commercial Spaces Reimagined
- ♦ Seamless Patron Flow
- ♦ Secure & Vibrant



AUTOMATED PARKING



Architectural Rendering



CONVENIENCE FROM ARRIVAL TO DEPARTURE

EFFORTLESS ♦ INTELLIGENT ♦ SECURE

Powered by the Automated Guided Vehicle (AGV) system with dual-core technology and coordinated robotic operations; K7 ensures an effortless parking experience that is precise, efficient and safe. This futuristic solution eliminates the hassle of finding bays, while securing vehicles and belongings in a fully automated, human-free environment.

Upon arrival, vehicle is handed over at the Valet Drop-Off. Guest can then unwind in the Premium Departure Lounge, where retrieval is made swift for a smooth exit.



Architectural Rendering

- ◆ AGV Parking Tech
- ◆ Valet Convenience
- ◆ 890 Wide Bays
- ◆ Secure Enclosure
- ◆ Departure Lounge
- ◆ Swift Retrieval (2.5 Mins)
- ◆ EV Charging
- ◆ Self Parking Option

A FRESH INDEPENDENT GROCER MARKET EXPERIENCE

DAILY SHOPPING REDEFINED

Market Hall is a modern evolution of the traditional morning market, designed to cater to new age lifestyle needs. It offers fresh produce at attractive prices within a cosy, clean and spacious air-conditioned setting.

A new concept featuring 55 kiosks and 10 dining terraces, it serves as a vibrant community focal point for daily essentials, gourmet discoveries and social interaction.

Independent grocers offer a diverse range of quality selections, from farm-to-table produce and daily catches to artisanal treats. Shoppers can also enjoy the excitement of price bargaining, creating a lively marketplace experience with fair value.

Operating from early morning until mall closing hours, grocers benefit from a dual-revenue model – selling fresh ingredients while serving them instantly through ready-to-enjoy offerings.

As a daily footfall-generating anchor that brings high yields for tenants and owners, it draws value-conscious and premium shoppers alike, driving continuous activity while enabling surrounding businesses to thrive.



- ◆ Footfall-Generating Anchor
Daily Traffic, Tenant Growth & Owner Value
- ◆ State-of-the-Art
Air Conditioned, Variety & Quality
- ◆ Curated Mix
Daily Fresh Essentials, Artisanal & Gourmet
- ◆ Bargain-Ready
Independent Grocers & Flexible Pricing



Architectural Rendering

MARKET HALL & SHOPS - G1



- 55 Kiosks** ◆ **151 sqft to 495 sqft** ◆ **10 Layouts** ◆ **10 Dining Terraces**
- Shop Office** ◆ **1,130 sqft to 6,975 sqft** ◆ **2 ½ Floors** ◆ **30 Units (Plus 2 on G2)**
- Patio** ◆ **2 Metres**



HIGH STREET

LEISURELY LIVINGdor Teragamo

◆ Trendy Alfresco Charm

◆ Shop · Dine · Unwind

FERMES

ROME Cafe

Parisian at Cafe

HIGH STREET

NEW LIFESTYLE CANVAS

- ◆ Soft Sunlight
- ◆ Natural Ventilation
- ◆ Shaded Paths
- ◆ Cosy Environment





CURATED SHOPPING

HIGH STREET

High Street is the strategic solution to old shop lot flaws and dead footfall, offering 48 exclusive units across 2½ storeys. Anchored by an elevated, 9-metre-wide pedestrian promenade that shades sunlight, this safe, car-free zone encourages extended stay-times and increased consumer spend in a family-friendly environment.

Each unit features a modern design with an expansive 2-metre-wide patio, built to eliminate the 'isolated shop lot issue' by creating a powerful cross-footfall synergy between dining and boutique retail. Naturally ventilated with an open-air airflow, the cosy ambience beautifully captures the shift in Shah Alam's premium spending power.

It is positioned as the town's next commercial benchmark and lifestyle destination – offering a profit-driven investment platform to attract quality patrons and ensure businesses consistently grow in this highly populated district.

- ◆ 2.5 Storey Shops
- ◆ Wide Patio (2 Metres)
- ◆ Brand Visibility



HIGH STREET

FASHIONABLE AVENUE

- ◆ Spacious Pedestrian Path
- ◆ Child-Friendly Area
- ◆ Car Free Zone
- ◆ Enhanced Security



HIGH STREET - UG1

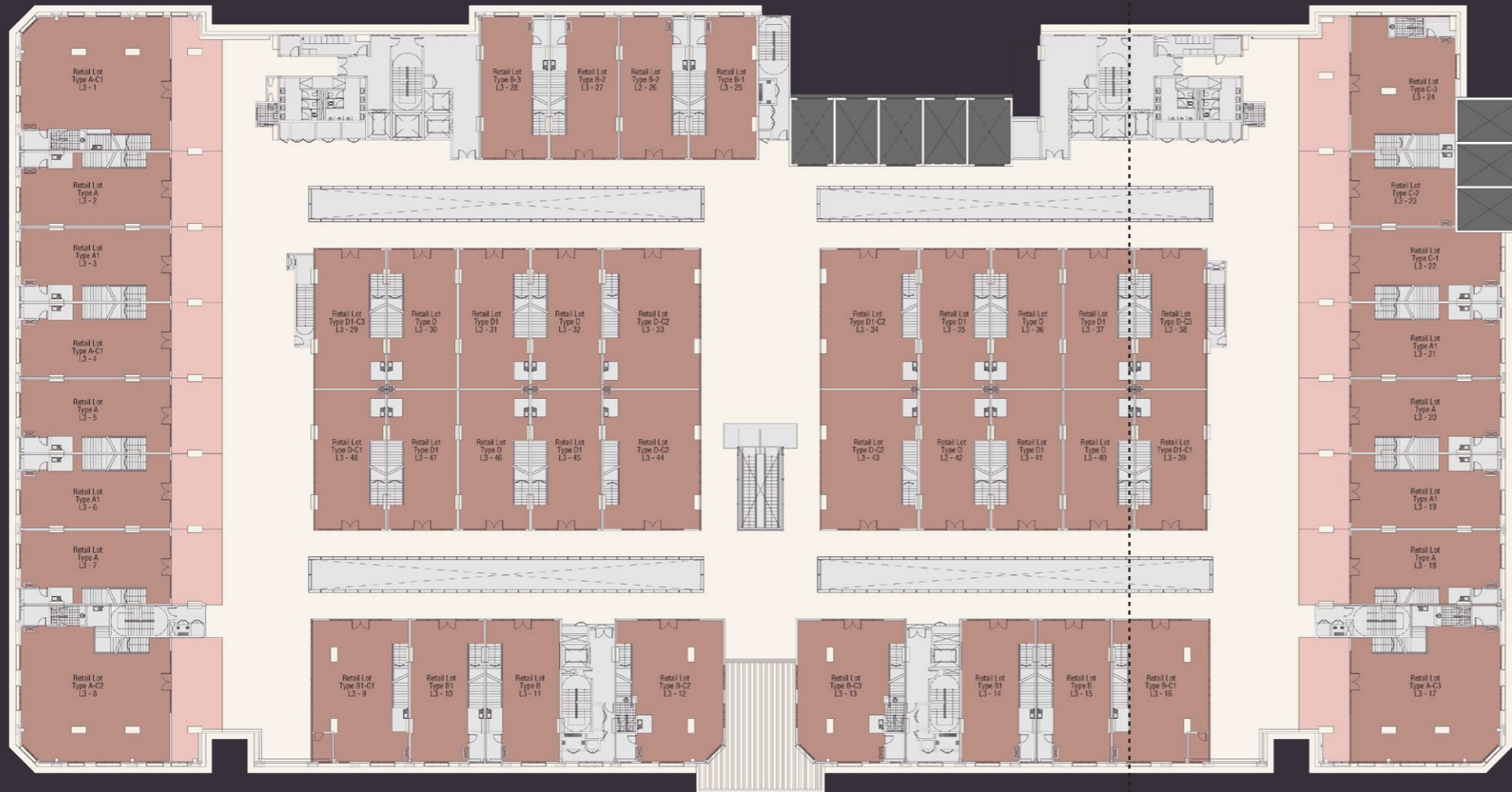

- Shop Office ◆ 1,130 sqft to 6,975 sqft ◆ 2 ½ Floors ◆ 48 Units
- Patio ◆ 2 Metres

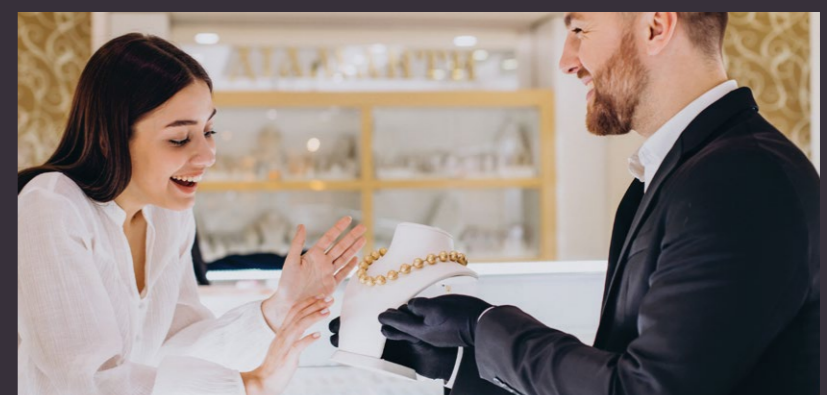

2.5-STOREY UNIT

SMARTER USE OF SPACE



- Education & Enrichment Hub – UG2
- High Street – UG1
- Personal Wellness – G2
- Market Hall – G1

FLEXIBLE MULTI-LEVEL LAYOUT

	1 FLOOR	UG2 SHOPS	<ul style="list-style-type: none"> ◆ 48 Shop Units ◆ 2 ½ Floors ◆ 2-Meter Patio ◆ 9-Meter-Wide Walkway
	½ FLOOR 1 FLOOR	UG1 SHOPS	
	1 FLOOR	G2 SHOPS	<ul style="list-style-type: none"> ◆ 32 Shop Units ◆ 2 ½ Floors ◆ 55 Market Kiosks ◆ 10 Dining Terraces
	½ FLOOR 1 FLOOR	G1 SHOPS	
		G1 MARKET HALL	

ACHIEVING HOLISTIC EQUILIBRIUM

PERSONAL WELLNESS

- ◆ Grooming & Aesthetics
- ◆ State-of-the-Art Fitness
- ◆ Healthcare & Therapeutics

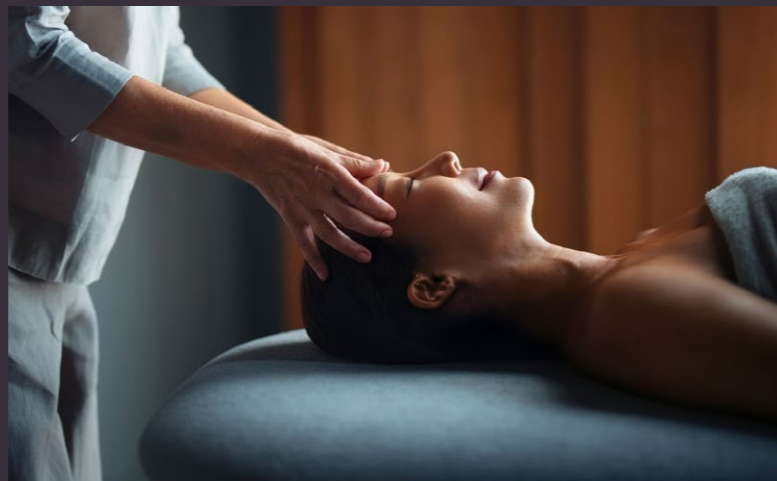

THE INTELLECTUAL BENCHMARK

EDUCATION & ENRICHMENT

- ◆ Premier Learning Centres
- ◆ Curated Programmes
- ◆ Growth & Development



Architectural Rendering

SURAU

FACILITIES

Honouring tradition with a cosy, aesthetic design, this modern Surau provides a comfortable environment as the first go-to space for daily prayers.

Complete with dedicated ablution facilities, its seamless integration ensures visitors can fulfil their routines and easily navigate back to the vibrant commercial area.

- ◆ Modern Design
- ◆ Cosier Space
- ◆ Seamless Accessibility

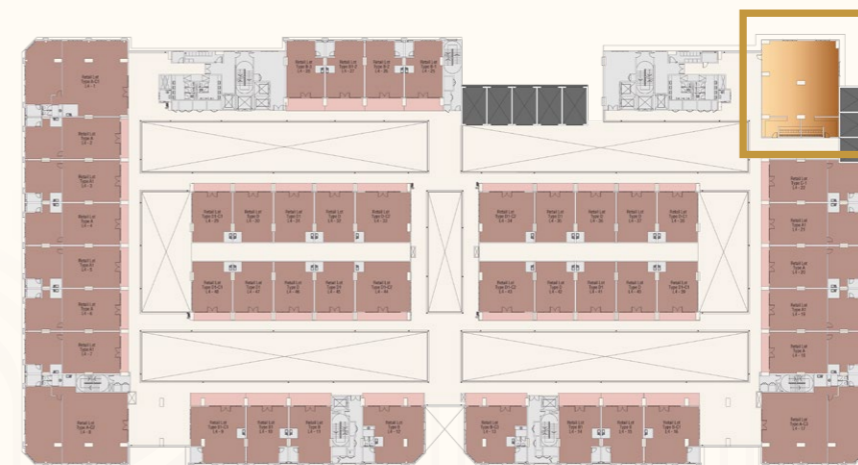

◆ Surau 2,573 sqft
(Covers Ablution / Wash Area)

UG2 - Surau

SUSTAINABLE BUILDING FEATURES

SMART DESIGN ELEMENTS

SUN PATH & SPATIAL ORIENTATION

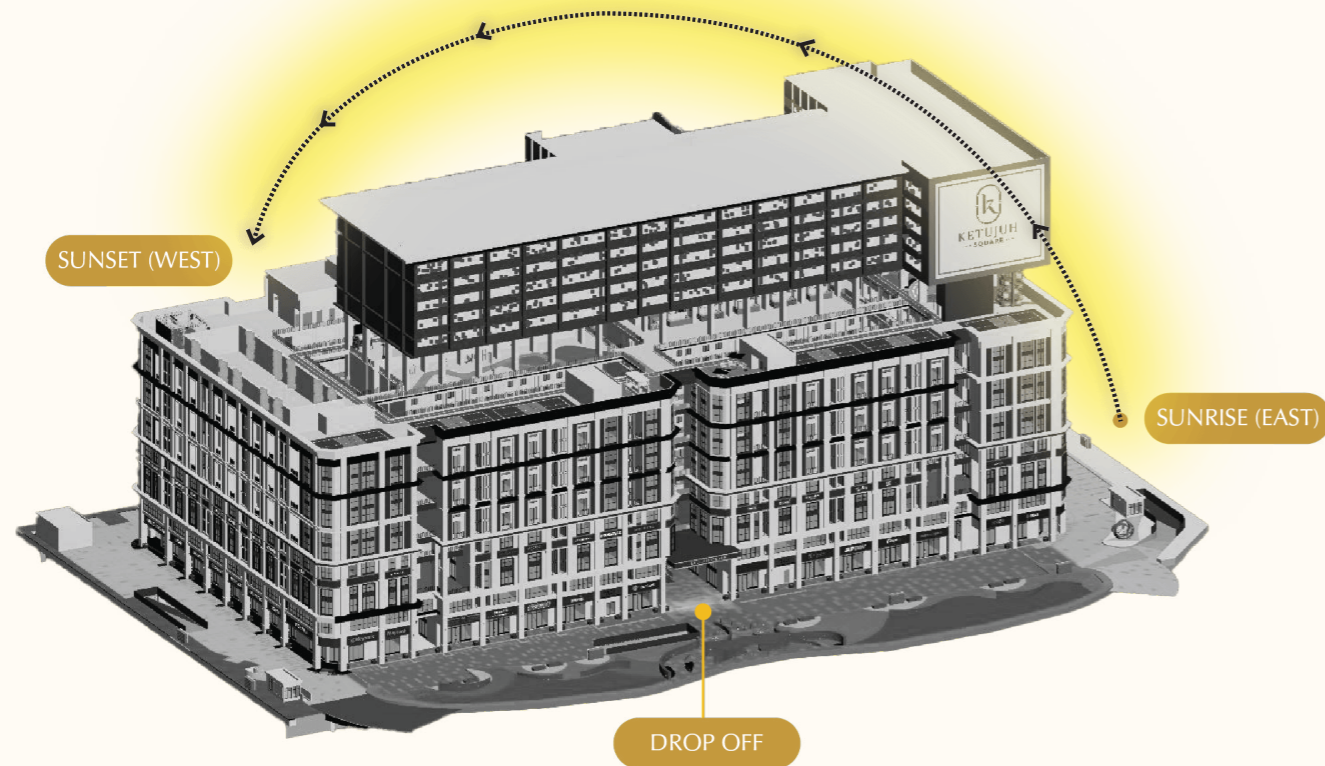

CHILLED WATER AIR CONDITIONING SYSTEM

Harnessing chilled water technology for AC cooling system to optimise electrical consumption & reduce CO₂.

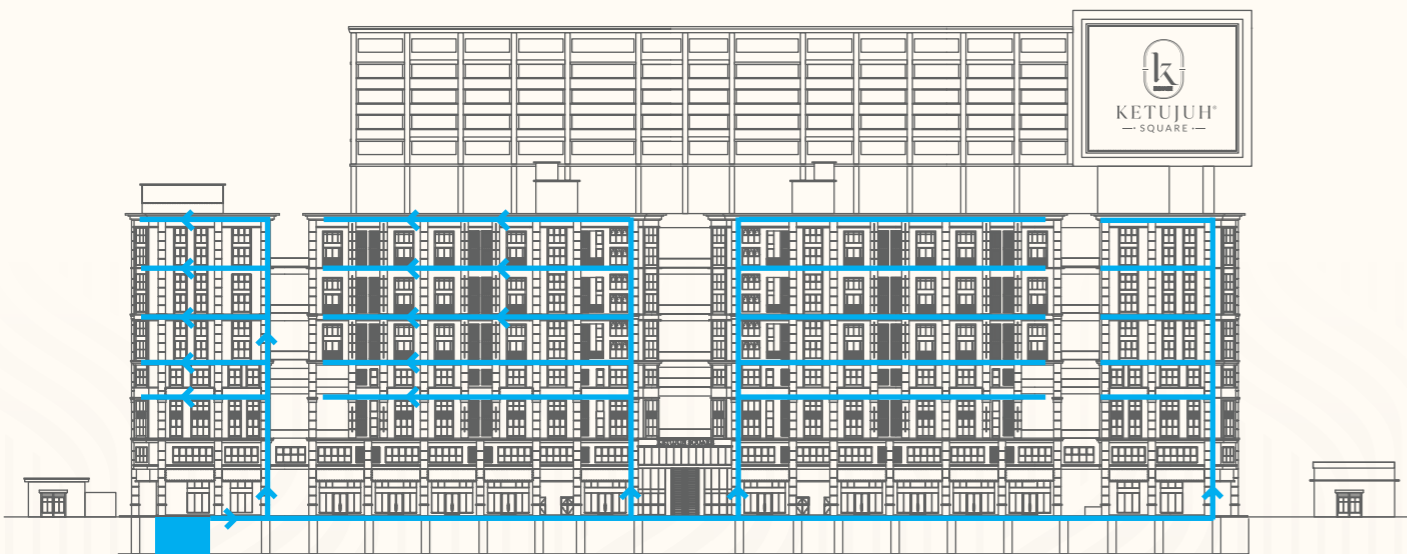

OPTIMAL DAYLIGHT

Natural light illuminates pathways while maintaining cool, shaded environments.

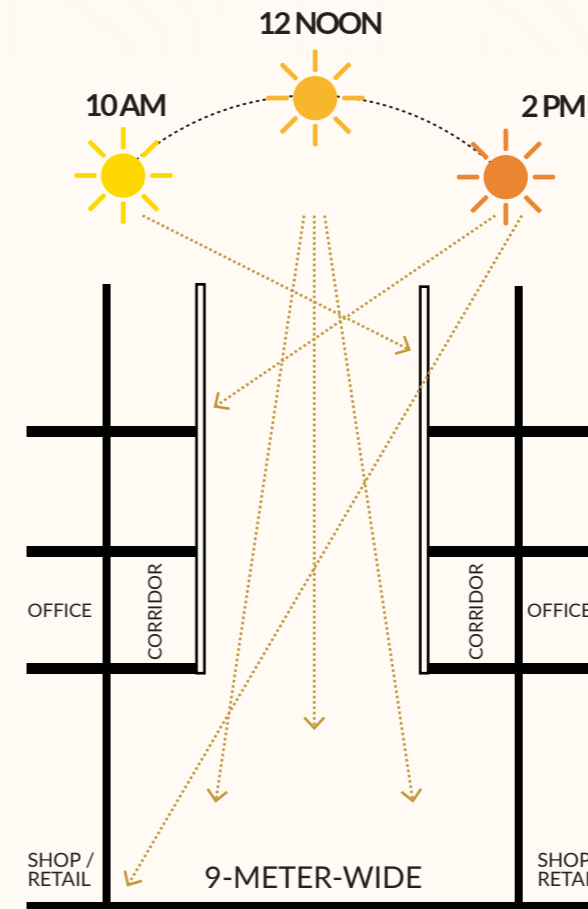

AIR CIRCULATION

Voids draw in fresh air while channeling heat out, utilising wide corridors to optimise cross-ventilation.

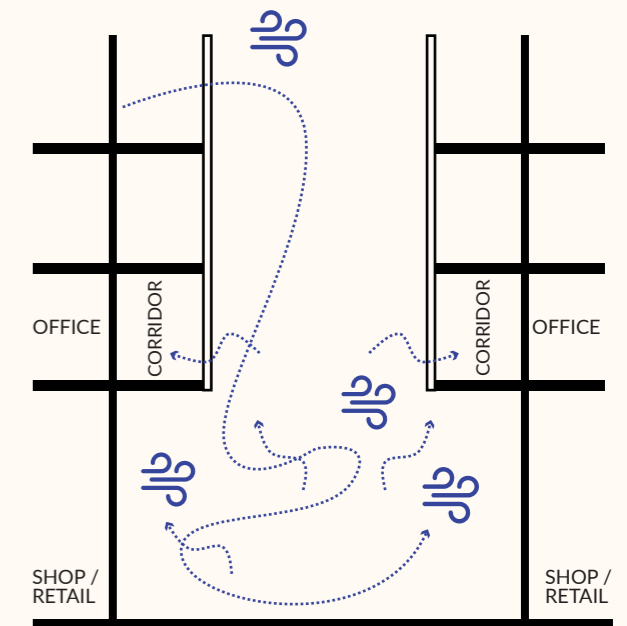

HIGH STREET

Double Panel

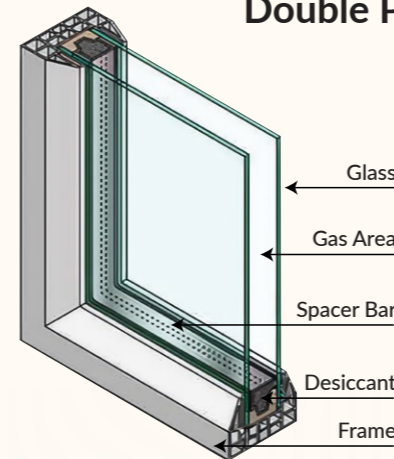

DOUBLE GLAZED WINDOW & DOOR PANELS

High-performance glazing ensures superior insulation & UV heat reduction.

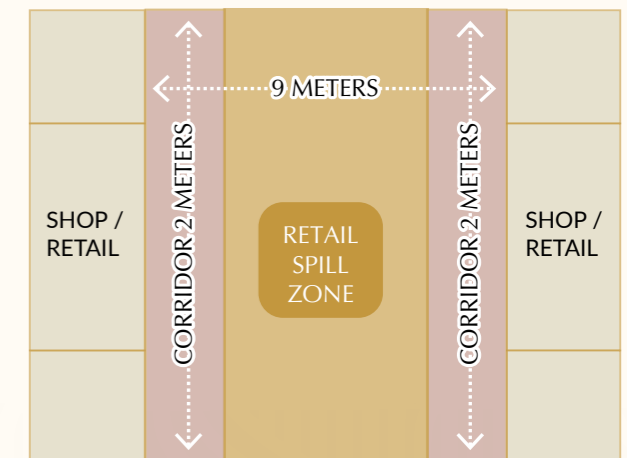

SPACIOUS PEDESTRIAN PATH

Wider paths that integrate indoor-outdoor flow for premium al fresco retail & dining.

EPICENTRE OF COMMERCE. DESTINATION FOR LIFESTYLE.

K7 is positioned at the nexus where major infrastructure links converge, solidifying its status as the city's most essential commercial and lifestyle destination.

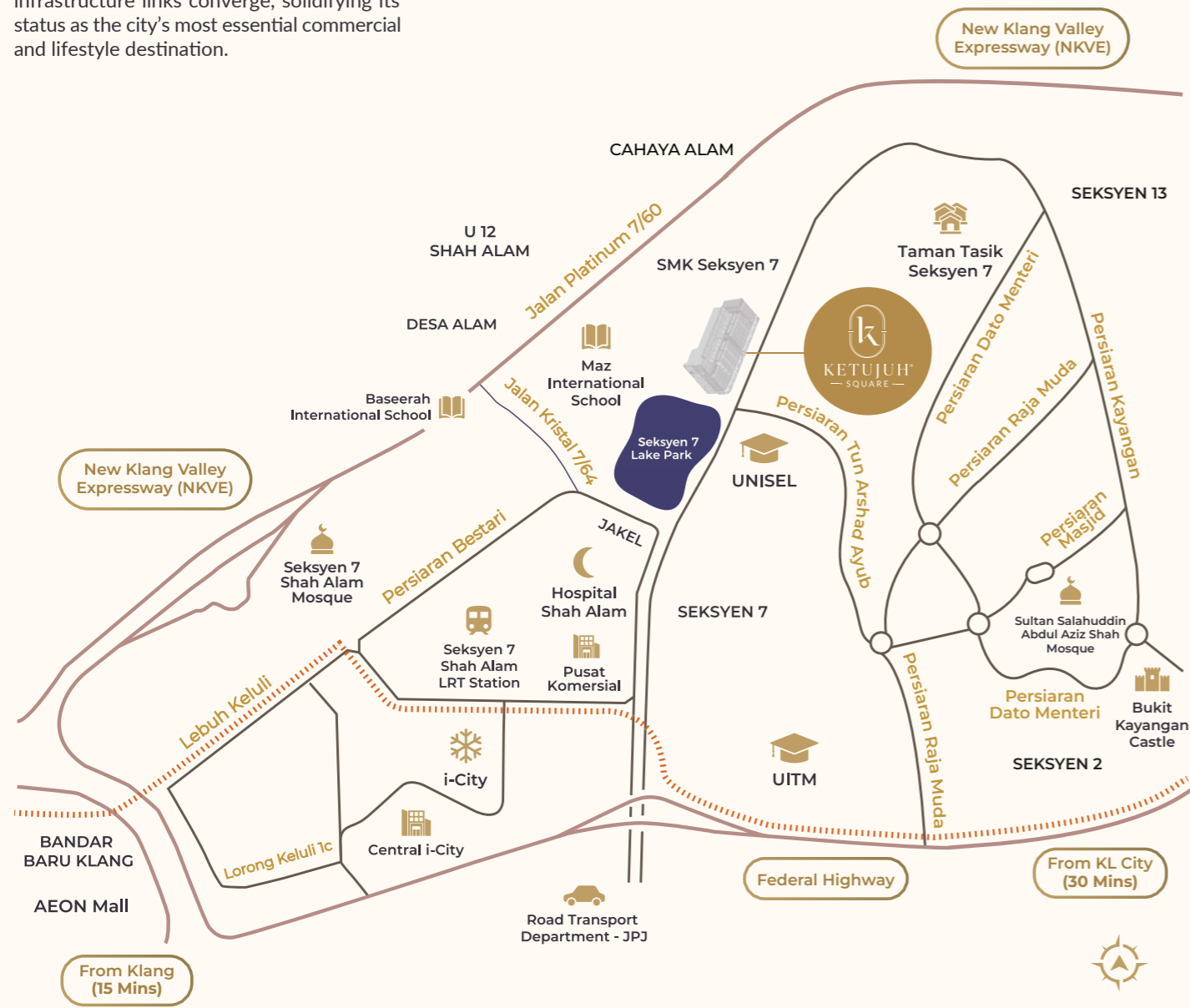

ALL WITHIN REACH

EDUCATIONAL INSTITUTIONS

- 350m SMK Seksyen 7
- 2.1km Universiti Selangor (UNISEL)
- 2.1km MAZ International School
- 3.4km SK Seksyen 7
- 4.6km UiTM Shah Alam
- 5.1km Brainy Bunch Seksyen 7
- 12.5km Greenview Islamic International School



MEDICAL FACILITIES

- 2.8km Hospital Shah Alam
- 6.8km Avisena Specialist Hospital
- 7.9km KPJ Klang Specialist Hospital
- 8.5km MSU Medical Centre

PUBLIC TRANSPORT

- 2.1km Rapid KL Station, UNISEL
- 3.3km Smart Selangor Station, Petronas Seksyen 7
- 4.5km LRT 3, UiTM Shah Alam
- 8.4km Shah Alam KTM Station
- 8.6km Bukit Badak KTM Station
- 9.4km Padang Jawa KTM Station
- 9.9km Klang KTM Station



BANKS

- 4.2km Mercu Maybank, i-City
- 4.6km Bank Islam UiTM
- 5.5km RHB Bank, Jalan Niaga
- 6.0km Maybank Intan Millennium
- 8.3km Bank Rakyat, Bandar Baru Klang



HIGHWAYS

- 6.2km Federal Highway
- 8.2km New Klang Valley Expressway (NKVE)
- 11.4km North-South Expressway Central Link (ELITE)
- 13.9km Shah Alam Expressway (KESAS)
- 17.5km Damansara-Puchong Expressway (LDP)
- 21.9km Sprint Expressway

SHOPPING MALLS

- 4.7km Central i-City
- 5.1km PKNS Complex Shah Alam
- 5.1km Plaza Alam Sentral
- 6.0km SACC Mall
- 6.4km AEON Mall
- 6.7km Lotus's Shah Alam



LEISURE & RECREATIONAL AREAS

- 1.7km Taman Tasik, Seksyen 7
- 3.2km Taman Botani, Shah Alam
- 3.9km Central i-City & Water World
- 4.1km Wet World Water Park, Shah Alam
- 4.2km Taman Tasik Shah Alam

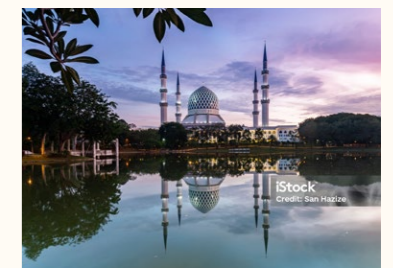



 VISIT



Sales Gallery
43, Jalan Plumbum
R7/R, Seksyen 7, 40000
Shah Alam, Selangor
Open Daily: 10am – 6pm

ENQUIRE



 03 8966 3888
 010 882 8818
 k7.com.my
 enquiry@k7.com.my

A PRESTIGIOUS DEVELOPMENT BY



MARKETING AGENT



Thorpe Nahar Development Sdn. Bhd. 202201004145 (1449842-W).
Wholly owned subsidiary of SLS Alpha Development Sdn. Bhd. 202001016522 (1372842-X).
All rights reserved. No part of this document may be reproduced, stored in a retrieval system
or transmitted in any form or by any means (electronic, mechanical, photocopying, recording
or otherwise) without the permission of the copyright owner.

ALL YOUR
NEEDS IN
ONE HUB

BLOCK

A

TYPE A-C1 (G)

2½ STOREY
SHOP / OFFICE
5,726 SQFT

DIAGRAMMATIC SECTION

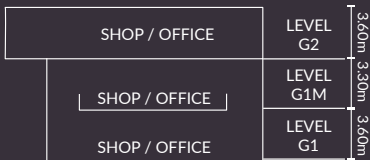

TYPE A - C1 (G)

GROUND FLOOR

1½ STOREY
SHOP

3,078 SQFT

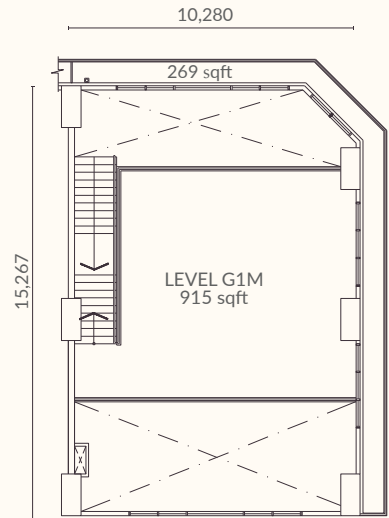
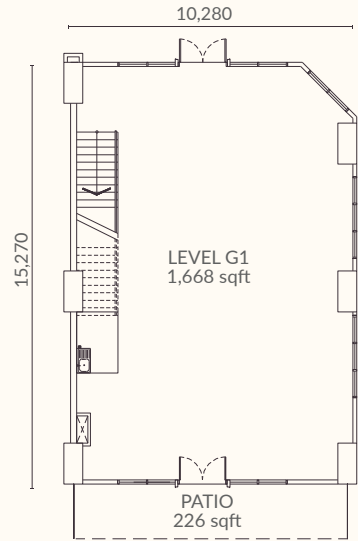

TYPE A - C1 (G)

1 STOREY
SHOP

2,648 SQFT

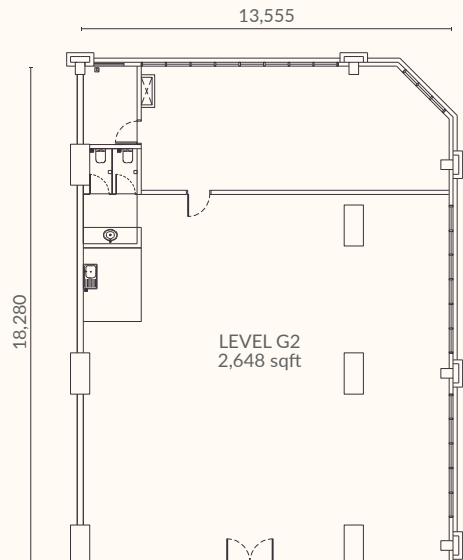

SPECIFICATION

LEVEL G1, G1M AND LEVEL G2
(Intermediate & Corner Units)

Structure	Reinforced Concrete					
Wall	Lightweight Block					
Roof Frame & Cover	Reinforced Concrete Flat Roof / Metal Roof					
Ceiling	Skim Coat And Paint					
Window	Aluminium Frame Glass					
Doors Main Entrance Others	Aluminium Frame Glass Doors Flush Door					
Ironmongery	Quality Locksets					
Wall Finishes	All Types (Unless Indicated)					
External Shop / Office	Cement Render And Paint					
Internal Shop / Office	Skim Coat					
Shop Toilets	Tiles (Selected Corner Units Only)					
AC Ledge / Compartment	Skim Coat And Paint					
Floor Finishes						
Shop / Office	Cement Render					
Shop Toilets (Selected Corner Units)	Tiles (Selected Corner Units Only)					
AC Ledge / Compartment	Cement Render					
Sanitary And Plumbing Fittngs	Types					
	Intermediate G1 & G1M		Intermediate G2		Corner G1 & G1M	Corner G2
	A	B-3	A	B-C1	A-C1	A-C1
	A1	B-C1	A1	B1-C1	A-C2	A-C2
B	B1-C1	B	B-C2	A-C3	A-C3	
B1	B-C2	B1	B-C3	A-C3A	C-M3	
B-1	B-C3	B-1	C-M1			
B-2	C-1	B-2	C-M2			
B1-2	C-2	B1-2	C-1			
		B-3	C-2			
Pantry Sink	1		1		1	1
Water Closet	-		-		-	2
Wash Basin	-		-		-	1
Water Tap	1		1		1	2
Bidet Tap	-		-		-	2
Toilet Roll Holder	-		-		-	2
Electrical Installation						
Power Supply 60A Phase	Three		Three		Three	Three
Distribution Board	1		1		1	1
Lighting Point	4		1		4	4
13A Power Point	2		1		2	1
Door Bell	-		1		-	1
Fiber Wall Socket	1		1		1	1
Speaker Points	2		1		2	1
Emergency Light	2		1		2	1
Keluar Sign	2		1		2	1
LPG Recticulation						
LPG Tap Point	1		-		1	-

BLOCK

A

TYPE A-C1 (G) RENOVATION PLAN

2 ½ STOREY
SHOP / OFFICE
6,178 SQFT

DIAGRAMMATIC SECTION

SHOP / OFFICE	LEVEL G2	3.60m
SHOP / OFFICE	LEVEL G1M	3.30m
SHOP / OFFICE	LEVEL G1	3.60m

TYPE A - C1 (G)

GROUND FLOOR

1 ½ STOREY
SHOP

3,530 SQFT

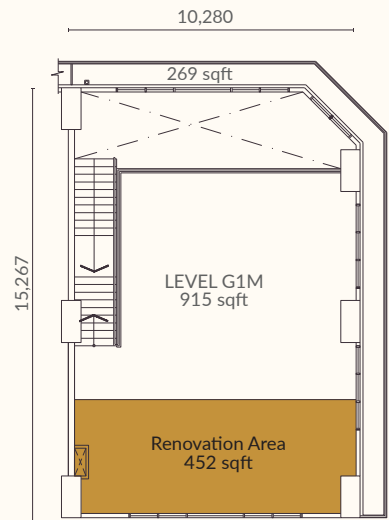
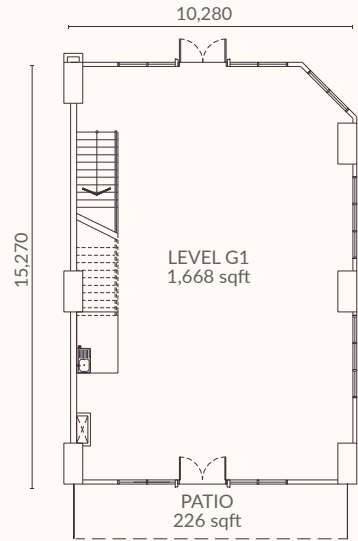

TYPE A - C1 (G)

1 STOREY
SHOP

2,648 SQFT

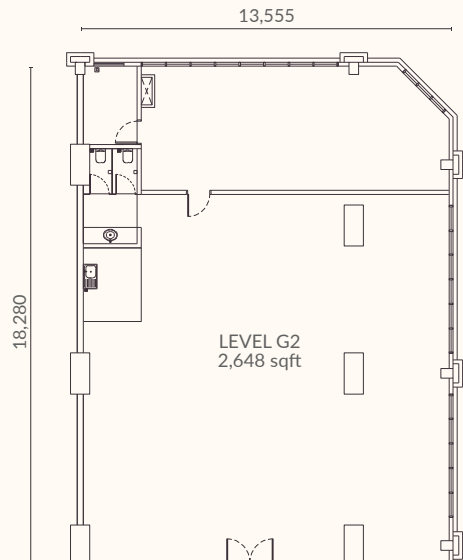

BLOCK

A

TYPE A-C1 (UG)

2 1/2 STOREY
SHOP / OFFICE
6,641 SQFT

DIAGRAMMATIC SECTION

SHOP / OFFICE	LEVEL UG2	3.60m
SHOP / OFFICE	LEVEL UG1M	3.30m
SHOP / OFFICE	LEVEL UG1	3.60m

TYPE A - C1 (UG)

1 1/2 STOREY
SHOP

3,993 SQFT

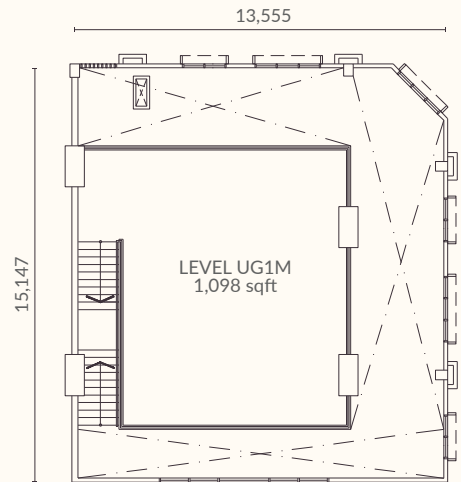
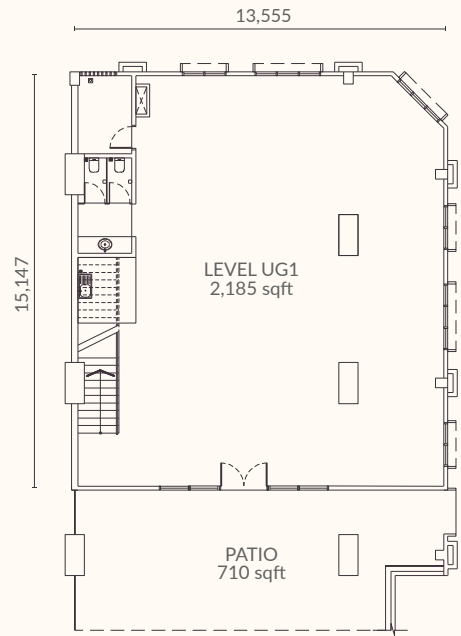

TYPE A - C1 (UG)

1 STOREY
SHOP

2,648 SQFT

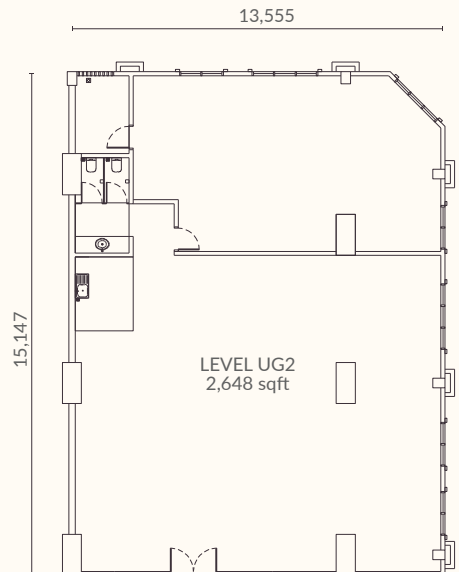

SPECIFICATION

LEVEL UG1, UG1M AND LEVEL UG2
(Intermediate & Corner Units)

Structure	Reinforced Concrete								
Wall	Lightweight Block								
Roof Frame & Cover	Reinforced Concrete Flat Roof / Metal Roof								
Ceiling	Skim Coat And Paint								
Window	Aluminium Frame Glass								
Doors Main Entrance Others	Aluminium Frame Glass Doors Flush Door								
Ironmongery	Quality Locksets								
Wall Finishes	All Types (Unless Indicated)								
External Shop / Office	Cement Render And Paint								
Internal Shop / Office	Skim Coat								
Shop Toilets	Tiles (Selected Corner Units Only)								
AC Ledge / Compartment	Skim Coat And Paint								
Floor Finishes									
Shop / Office	Cement Render								
Shop Toilets (Selected Corner Units)	Tiles (Selected Corner Units Only)								
AC Ledge / Compartment	Cement Render								
Sanitary And Plumbing Fittngs	Types								
	Int. - UG1 & UG1M	Intermediate UG2		Intermediate UG1 & UG1M		Corner UG1 & UG1M	Corner UG1 & UG1M	Corner G2	Corner G2
	A A1 C-1 C-2	A A1 B B-1 B-2 B1-2 B-3 B-C1	B1-C1 C-1 D D1 D-C1 D1-C1 D1-C2 D1-C2	B1-C1 B-C1 B1 B B-1 B-2 B1-2 B-3 D1-C3	D-C3 D-C1 D1-C1 D D1 D-C2 D1-C2	A-C1 A-C2 A-C3	B-C2 B-C3	A-C1 A-C2 A-C3 C-3	B-C3 B-C2
Pantry Sink	1	1		1		1	1	1	1
Water Closet	-	-		-		2	2	2	2
Wash Basin	-	-		-		1	1	1	1
Water Tap	1	1		1		2	2	2	2
Bidet Tap	-	-		-		2	2	2	2
Toilet Roll Holder	-	-		-		2	2	2	2
Electrical Installation									
Power Supply 60A Phase	Three	Three		Three		Three	Three	Three	Three
Distribution Board	1	1		1		1	1	1	1
Lighting Point	4	2		3		7	6	4	5
13A Power Point	2	1		2		2	2	1	1
Door Bell	-	1		-		-	-	1	1
Fiber Wall Socket	1	1		1		1	1	1	1
Speaker Points	2	1		2		2	2	1	1
Emergency Light	2	1		2		2	2	1	1
Keluar Sign	1	1		1		2	2	1	1
LPG Recticulation									
LPG Tap Point	1	-		1		1	1	-	1

BLOCK

A

TYPE A-C1 (UG) RENOVATION PLAN

2½ STOREY
SHOP / OFFICE
6,964 SQFT

DIAGRAMMATIC SECTION

SHOP / OFFICE	LEVEL UG2	3.60m
SHOP / OFFICE	LEVEL UG1M	3.30m
SHOP / OFFICE	LEVEL UG1	3.60m

TYPE A - C1 (UG)

1½ STOREY
SHOP

4,316 SQFT

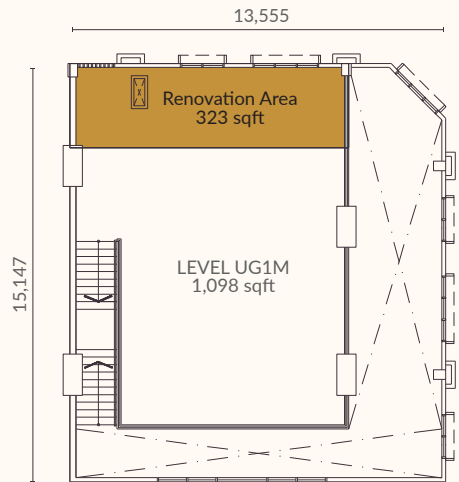
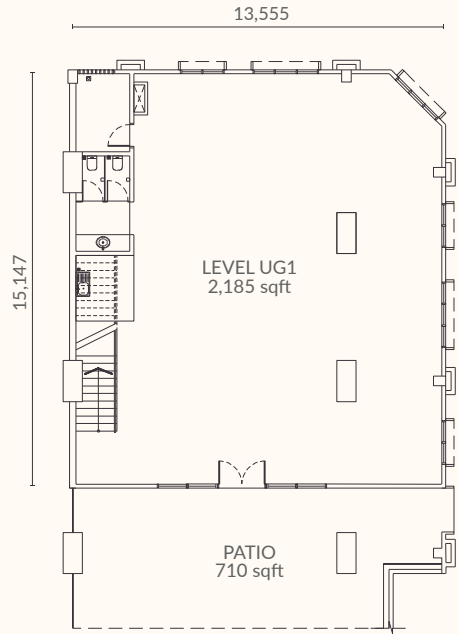

TYPE A - C1 (UG)

1 STOREY
SHOP

2,648 SQFT

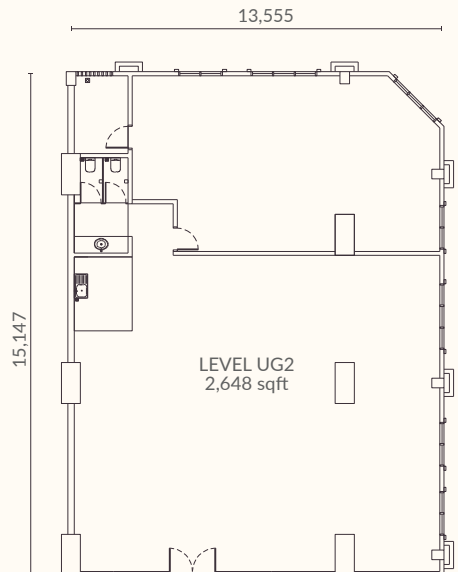

BLOCK

A

TYPE A (G)

2 ½ STOREY
SHOP / OFFICE
3,670 SQFT

DIAGRAMMATIC SECTION

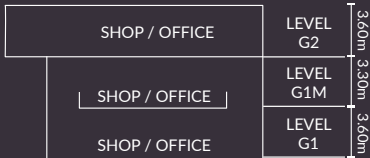

TYPE A (G)

GROUND FLOOR

1 ½ STOREY
SHOP

2,174 SQFT

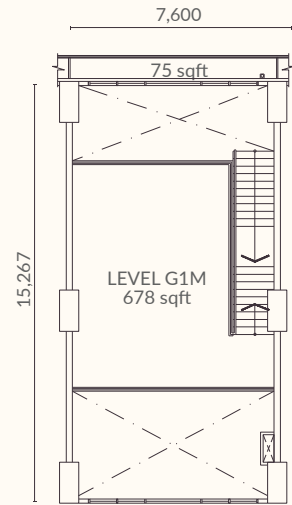
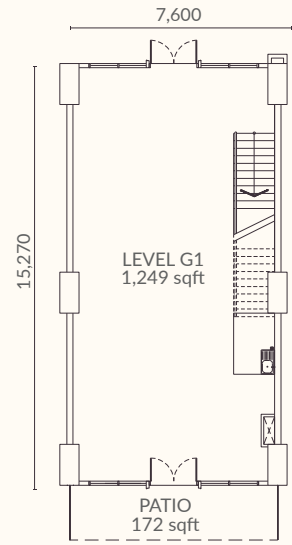

TYPE A (G)

1 STOREY
SHOP

1,496 SQFT

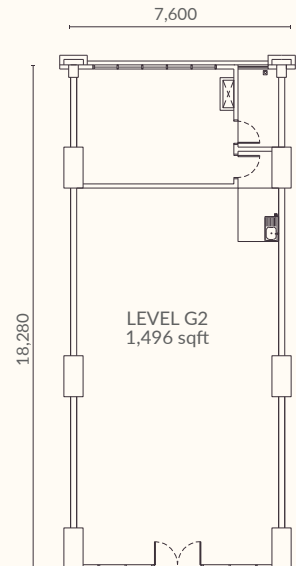

SPECIFICATION

LEVEL G1, G1M AND LEVEL G2
(Intermediate & Corner Units)

Structure	Reinforced Concrete					
Wall	Lightweight Block					
Roof Frame & Cover	Reinforced Concrete Flat Roof / Metal Roof					
Ceiling	Skim Coat And Paint					
Window	Aluminium Frame Glass					
Doors Main Entrance Others	Aluminium Frame Glass Doors Flush Door					
Ironmongery	Quality Locksets					
Wall Finishes	All Types (Unless Indicated)					
External Shop / Office	Cement Render And Paint					
Internal Shop / Office	Skim Coat					
Shop Toilets	Tiles (Selected Corner Units Only)					
AC Ledge / Compartment	Skim Coat And Paint					
Floor Finishes						
Shop / Office	Cement Render					
Shop Toilets (Selected Corner Units)	Tiles (Selected Corner Units Only)					
AC Ledge / Compartment	Cement Render					
Sanitary And Plumbing Fittngs	Types					
	Intermediate G1 & G1M		Intermediate G2		Corner G1 & G1M	Corner G2
	A	B-3	A	B-C1	A-C1	A-C1
	A1	B-C1	A1	B1-C1	A-C2	A-C2
B	B1-C1	B	B-C2	A-C3	A-C3	
B1	B-C2	B1	B-C3	A-C3A	C-M3	
B-1	B-C3	B-1	C-M1			
B-2	C-1	B-2	C-M2			
B1-2	C-2	B1-2	C-1			
		B-3	C-2			
Pantry Sink	1		1		1	
Water Closet	-		-		2	
Wash Basin	-		-		1	
Water Tap	1		1		2	
Bidet Tap	-		-		2	
Toilet Roll Holder	-		-		2	
Electrical Installation						
Power Supply 60A Phase	Three		Three		Three	
Distribution Board	1		1		1	
Lighting Point	4		1		4	
13A Power Point	2		1		1	
Door Bell	-		1		1	
Fiber Wall Socket	1		1		1	
Speaker Points	2		1		1	
Emergency Light	2		1		1	
Keluar Sign	2		1		1	
LPG Recticulation						
LPG Tap Point	1		-		-	

BLOCK

A

TYPE A (G) RENOVATION PLAN

2½ STOREY
SHOP / OFFICE
4,005 SQFT

DIAGRAMMATIC SECTION

SHOP / OFFICE	LEVEL G2	3.60m
SHOP / OFFICE	LEVEL G1M	3.30m
SHOP / OFFICE	LEVEL G1	3.60m

TYPE A (G)

GROUND FLOOR

1½ STOREY
SHOP

2,509 SQFT

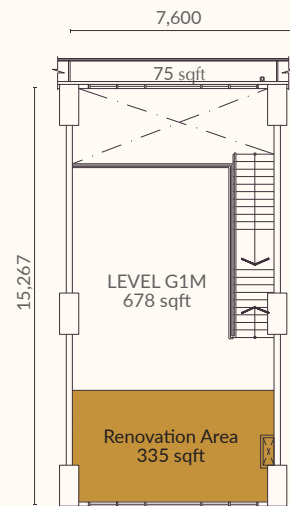
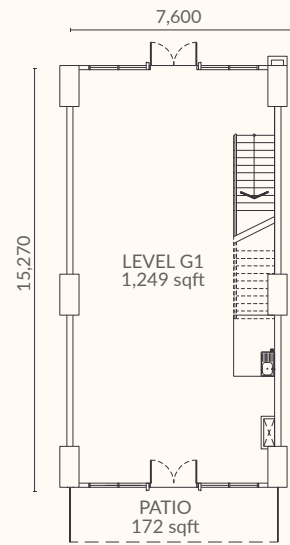

TYPE A (G)

1 STOREY
SHOP

1,496 SQFT

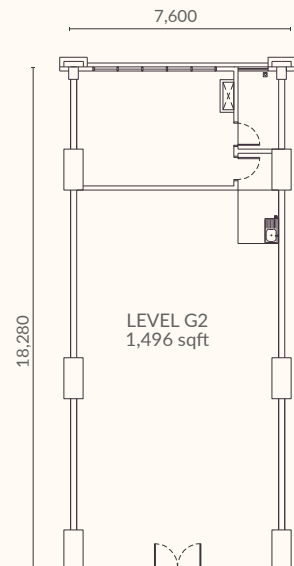

BLOCK

A

TYPE A (UG)

2½ STOREY
SHOP / OFFICE
3,606 SQFT

DIAGRAMMATIC SECTION



TYPE A (UG)

1½ STOREY
SHOP

2,099 SQFT

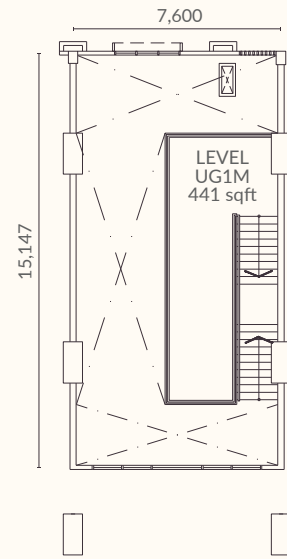
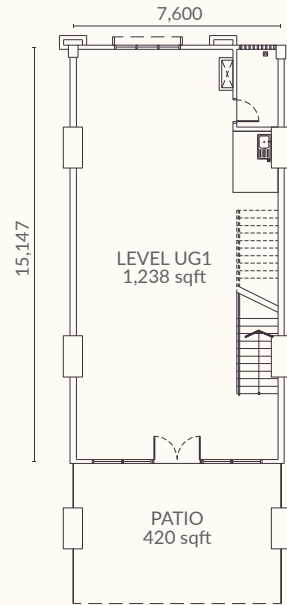

TYPE A (UG)

1 STOREY
SHOP

1,507 SQFT



SPECIFICATION

LEVEL UG1, UG1M AND LEVEL UG2
(Intermediate & Corner Units)

Structure	Reinforced Concrete								
Wall	Lightweight Block								
Roof Frame & Cover	Reinforced Concrete Flat Roof / Metal Roof								
Ceiling	Skim Coat And Paint								
Window	Aluminium Frame Glass								
Doors Main Entrance Others	Aluminium Frame Glass Doors Flush Door								
Ironmongery	Quality Locksets								
Wall Finishes	All Types (Unless Indicated)								
External Shop / Office	Cement Render And Paint								
Internal Shop / Office	Skim Coat								
Shop Toilets	Tiles (Selected Corner Units Only)								
AC Ledge / Compartment	Skim Coat And Paint								
Floor Finishes									
Shop / Office	Cement Render								
Shop Toilets (Selected Corner Units)	Tiles (Selected Corner Units Only)								
AC Ledge / Compartment	Cement Render								
Sanitary And Plumbing Fittngs	Types								
	Int. - UG1 & UG1M	Intermediate UG2		Intermediate UG1 & UG1M		Corner UG1 & UG1M	Corner UG1 & UG1M	Corner G2	Corner G2
	A	A	B1-C1	B1-C1	D-C3	A-C1	B-C2	A-C1	B-C3
	A1	A1	C-1	B-C1	D-C1	A-C2	B-C3	A-C2	B-C2
	C-1	B	D	B1	D1-C1	A-C3		A-C3	
	C-2	B1	D1	B	D			C-3	
		B-1	D-C1	B-1	D1				
		B-2	D1-C1	B-2	D-C2				
		B1-2	D-C2	B1-2	D1-C2				
		B-3	D1-C2	B-3					
		B-C1		D1-C3					
Pantry Sink	1	1		1		1	1	1	1
Water Closet	-	-		-		2	2	2	2
Wash Basin	-	-		-		1	1	1	1
Water Tap	1	1		1		2	2	2	2
Bidet Tap	-	-		-		2	2	2	2
Toilet Roll Holder	-	-		-		2	2	2	2
Electrical Installation									
Power Supply 60A Phase	Three	Three		Three		Three	Three	Three	Three
Distribution Board	1	1		1		1	1	1	1
Lighting Point	4	2		3		7	6	4	5
13A Power Point	2	1		2		2	2	1	1
Door Bell	-	1		-		-	-	1	1
Fiber Wall Socket	1	1		1		1	1	1	1
Speaker Points	2	1		2		2	2	1	1
Emergency Light	2	1		2		2	2	1	1
Keluar Sign	1	1		1		2	2	1	1
LPG Recticulation									
LPG Tap Point	1	-		1		1	1	-	1

BLOCK

A

TYPE A (UG) RENOVATION PLAN

2½ STOREY
SHOP / OFFICE
4,213 SQFT

DIAGRAMMATIC SECTION

SHOP / OFFICE	LEVEL UG2	3.60m
SHOP / OFFICE	LEVEL UG1M	3.30m
SHOP / OFFICE	LEVEL UG1	3.60m

TYPE A (UG)

1½ STOREY
SHOP

2,706 SQFT

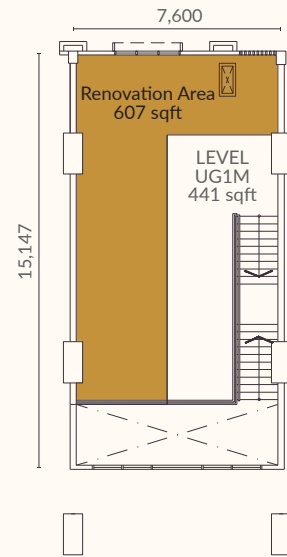
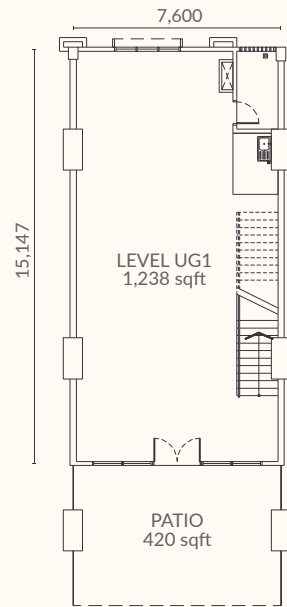

TYPE A (UG)

1 STOREY
SHOP

1,507 SQFT

